

Manufactured off-site
 Delivered to suit site conditions
 Light Steel frame
 Rigid and versatile
 Quick and clean installation
 High quality and flexible construction solution



MIVAN

With a dedicated operations office in the City of London and a design & manufacturing facility in Northern Ireland, Mivan has become one of the UK's leading interior fit-out and specialist joinery contractors.

Mivan is currently working on a number of high-profile commercial and residential projects in London and the South East. Mivan's current client base includes:

- Ballymore Properties
- Bennetts Associates
- Bovis Lend Lease
- Brookfield Construction
- Canary Wharf Contractors
- Denton Corker Marshall
- Kohn Pedersen Fox
- Laing O'Rourke
- Mace
- Sir Robert McAlpine
- Skanska UK
- Stanhope plc



Mivan would be pleased to supply reference contacts for any of our clients.

Mivan also has offices in Bucharest, Dubai and Cairo. For further details and full portfolio of services please visit our website.

www.mivan.com/modular
 Email: hq@mivan.com



Mivan Limited Certifications

Head Office:
Mivan Limited
 Newpark
 Greystone Road
 Antrim
 County Antrim
 BT41 2QN
 Northern Ireland

Tel: +44 (0)28 9448 1000
 Fax: +44 (0)28 9446 6338

London Office:
Mivan Limited
 1st Floor Pinnacle House
 23-26 St Dunstan's Hill
 London
 EC3R 8HN

Tel: +44 (0)207 623 9600
 Fax: +44 (0)207 623 9247

MIVAN modular™

Innovative off-site solutions
 from your leading interiors
 contractor

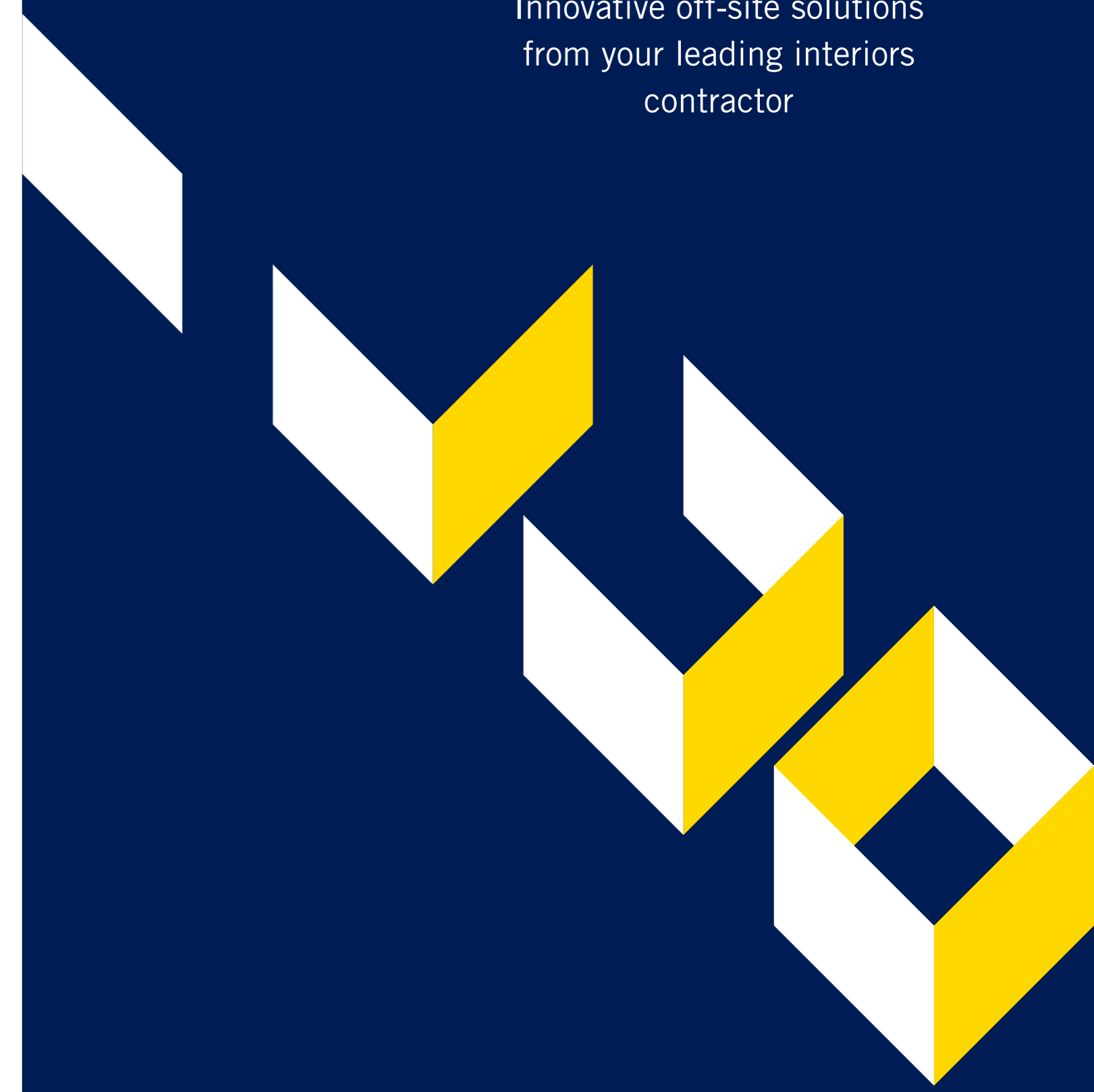

The product

Mivan Modular is a panel-based wall solution for washroom and other commercial interiors. Prefabricated in a quality-controlled, factory environment, Mivan Modular is an off-site solution from Mivan Limited, one of the UK's leading interiors contractors.

Bespoke Solution

Mivan Modular is delivered to site in full wall or smaller modular sections. Mivan Modular's galvanised light steel frame is a rigid and versatile solution which can be utilised to achieve a high-quality and flexible construction system. Mivan's award winning interior fit-out teams work closely with the client and architect to develop a full understanding of the project and design the 'best fit' solution to fulfil the brief.

Mivan Modular supports the full range of finishes including back-painted glass, marble, veneer or corian.

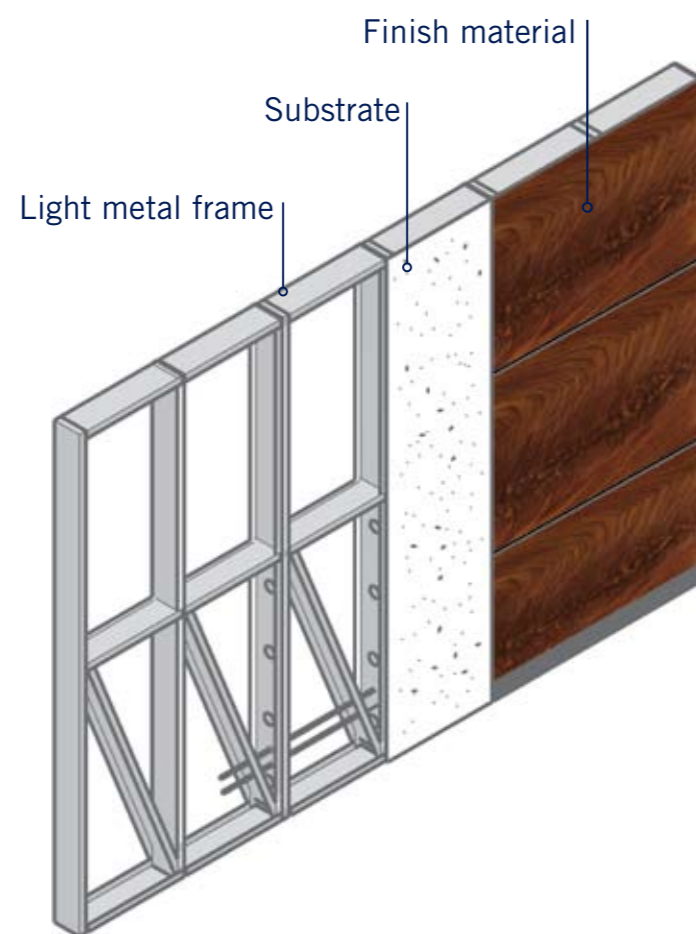

Benefits

How it works

Once sizes and details have been agreed with the client and / or project team, the fundamental concept and process behind Mivan Modular remains the same. In summary, the process and materials used are as follows:

The frame solution is a bespoke, cold-rolled galvanised steel section in either 65 or 100mm sections. Each section is pre-drilled and machined to accommodate services, self-locating using only one type of fixing. All panels are mounted on a simple extruded sub-frame. Flooring and ceilings are incorporated to suit site conditions.

Design Development

Mivan's in-house Design Team will work closely with the client and / or project architect, engineering an innovative and best value solution. The earlier that Mivan's Design Team can be engaged, the greater impact and value they will have in the end product.

The team have been using early concept designs from some of the world's leading architectural practices and transforming these into workable, manufacturing drawings in some of the UK's most prestigious projects.



Off Site fabrication

Mivan Modular is manufactured in an off-site environment, broken down and shipped to site. Pre-fabrication takes place in Mivan's 11,000m² factory at its global headquarters in Northern Ireland, one of the best-equipped joinery facilities in the UK. The off-site nature of Mivan Modular delivers key benefits:

- Straightforward site installation process reducing programmes and amount of labour required on-site
- Less waste on-site promoting cleanliness and improving safety
- Quality-controlled product in factory conditions
- Potential for reduced management costs on-site
- Reduced design & construction risk due to off-site manufacture
- Delivered to suit site conditions
- Bespoke modular manufacture allows product to be used for sites with limited access



Applications

See for yourself

Mivan invites architects, developers and main contractors to visit the fully assembled Mivan Modular prototype at Mivan's manufacturing facility in Antrim. To arrange a visit please contact a member of our Business Development team on 02894 481000.

Diverse applications

Although Mivan Modular has been initially developed for the commercial washroom environment, Mivan is confident that its fundamentals can be applied to various areas of construction interiors.

These include:

- Reception areas
- Boardrooms
- Meeting rooms

